

SPECIFICATIONS	
WEIGHT	350 LBS (158.6 KG)
ELECTRICAL	UNIVERSAL INPUT, 100V TO 240V VAC, 50/60 Hz POWER CONSUMPTION: 1500W (VA) MAX
AIR FEED	5 CFM/80 PSI OF CLEAN, DRY AIR
PASS-THROUGH	UP TO 5 INCHES
BAG THICKNESS	1.09 - 4.0 MIL
BAG SIZES	WIDTH: 2 to 12 INCHES / LENGTH: 3 to 20 INCHES
WEIGHT CAPACITY	UP TO 5 LBS (WITH LOAD SHELF)

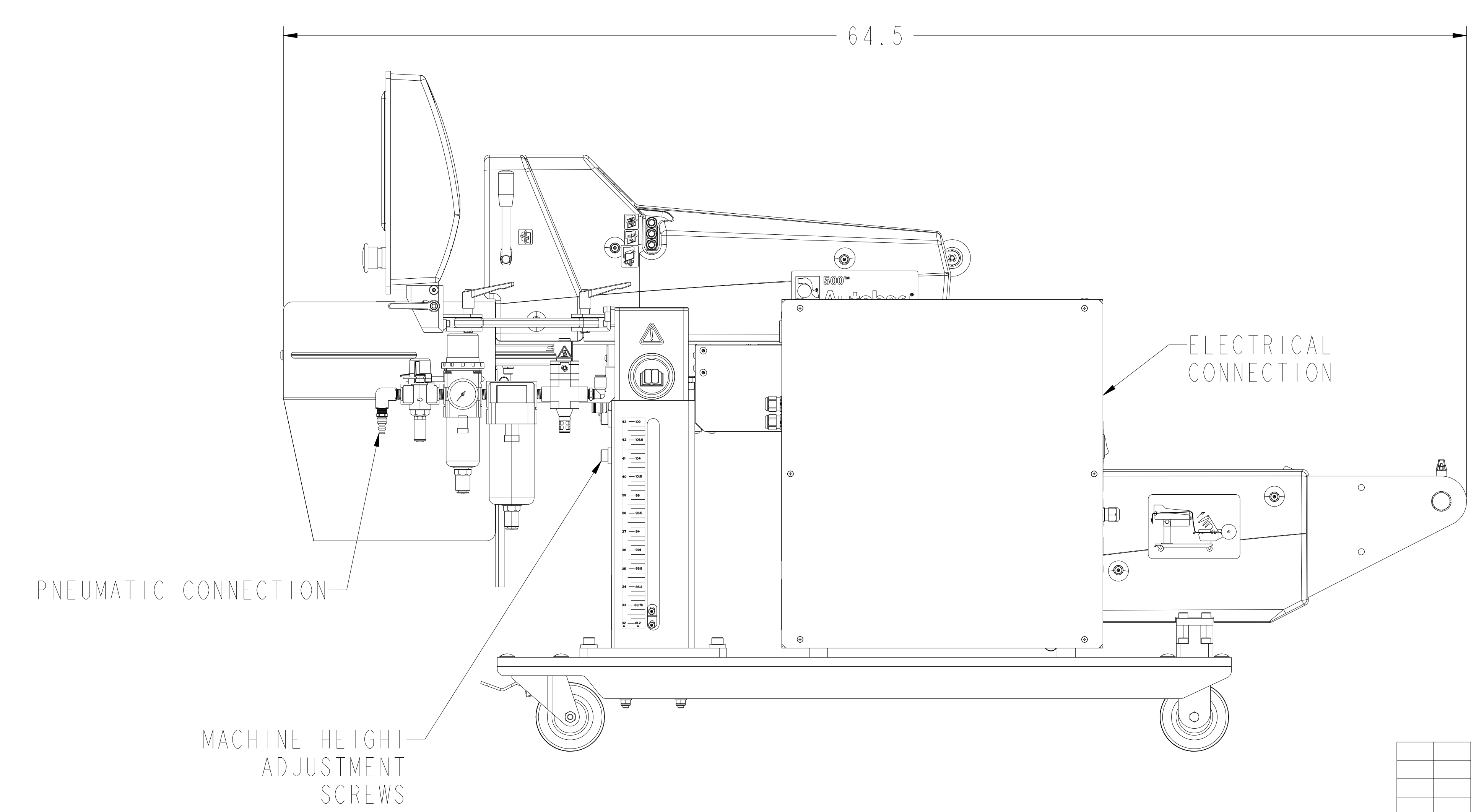
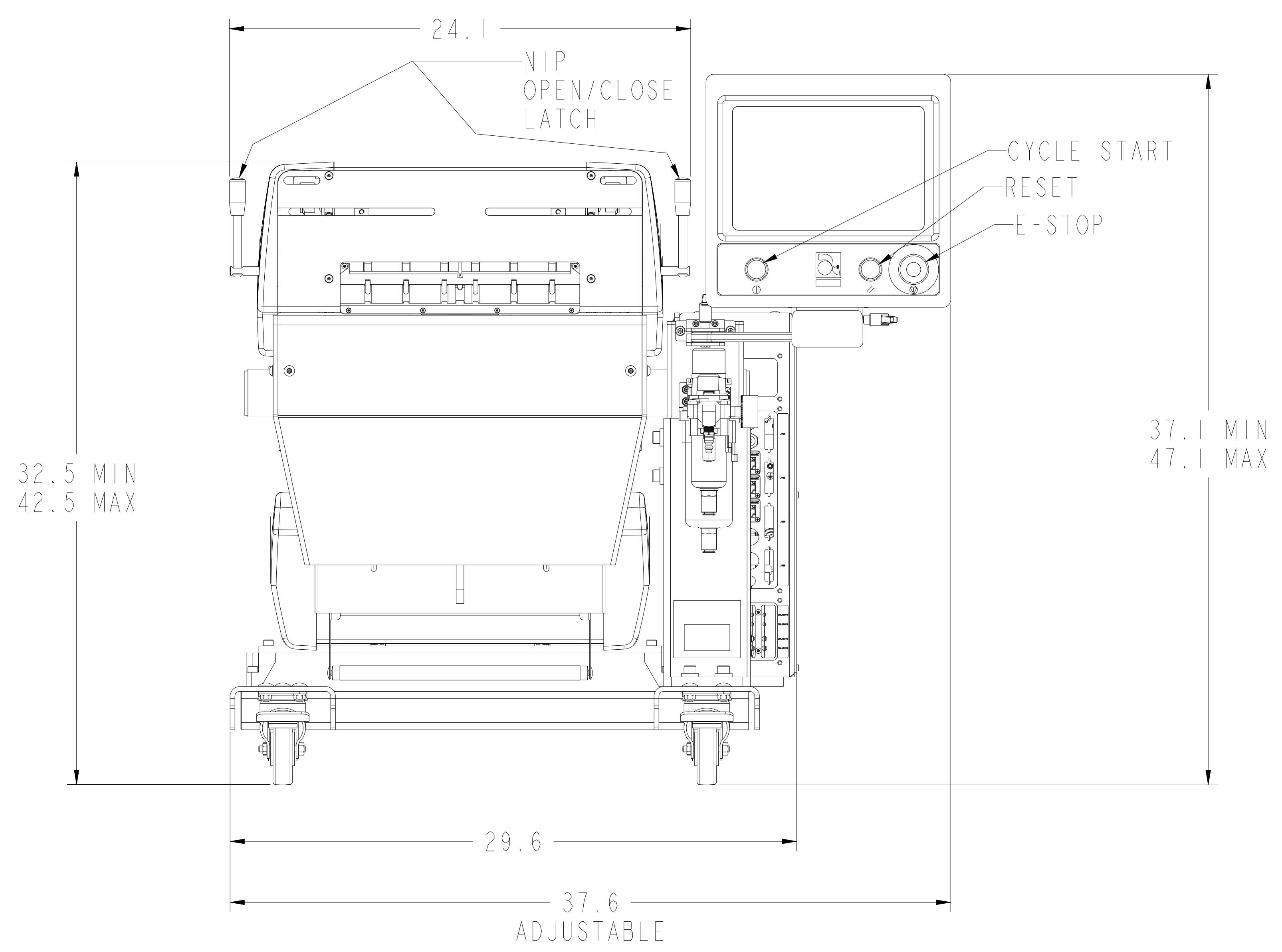
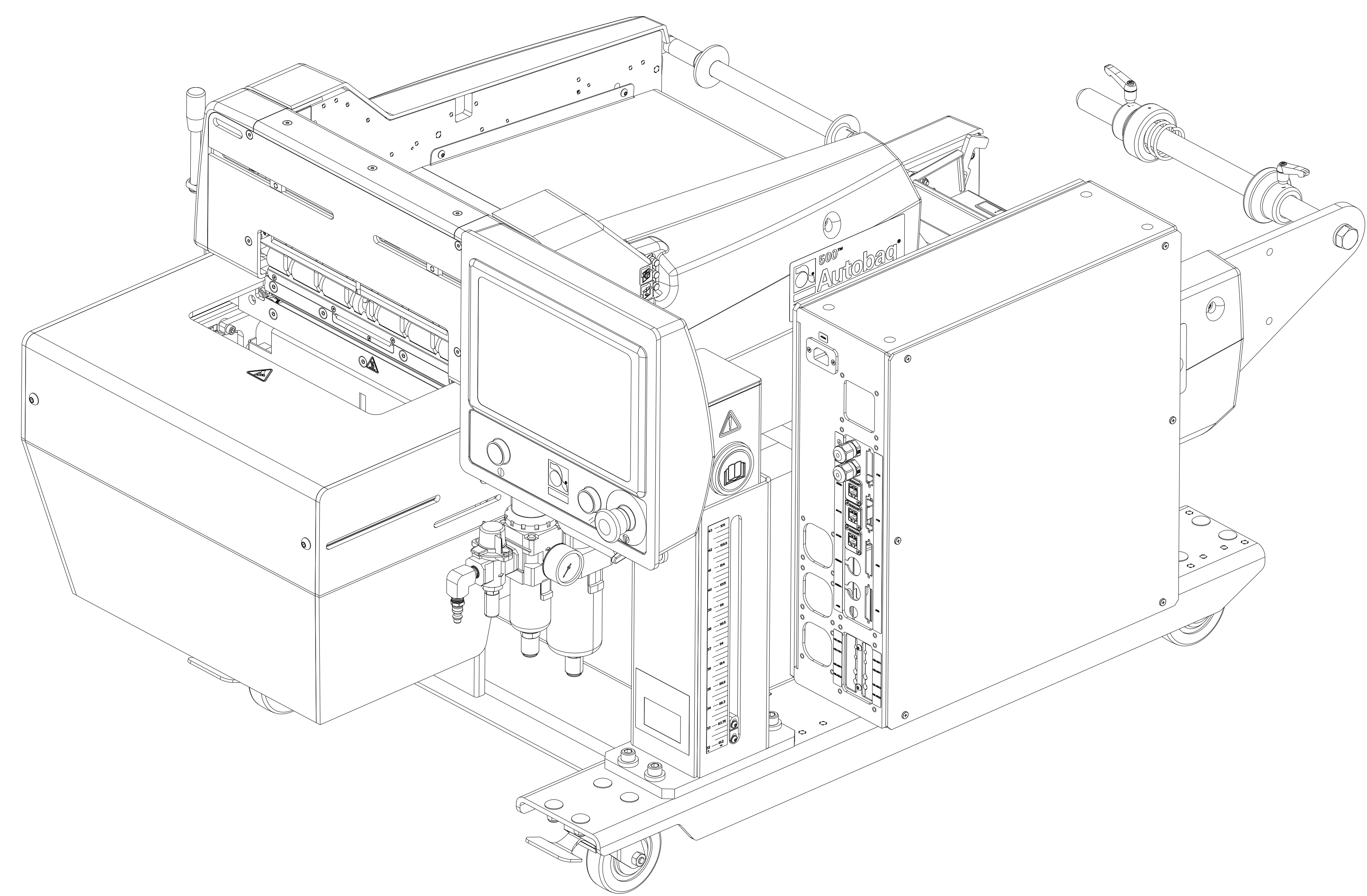
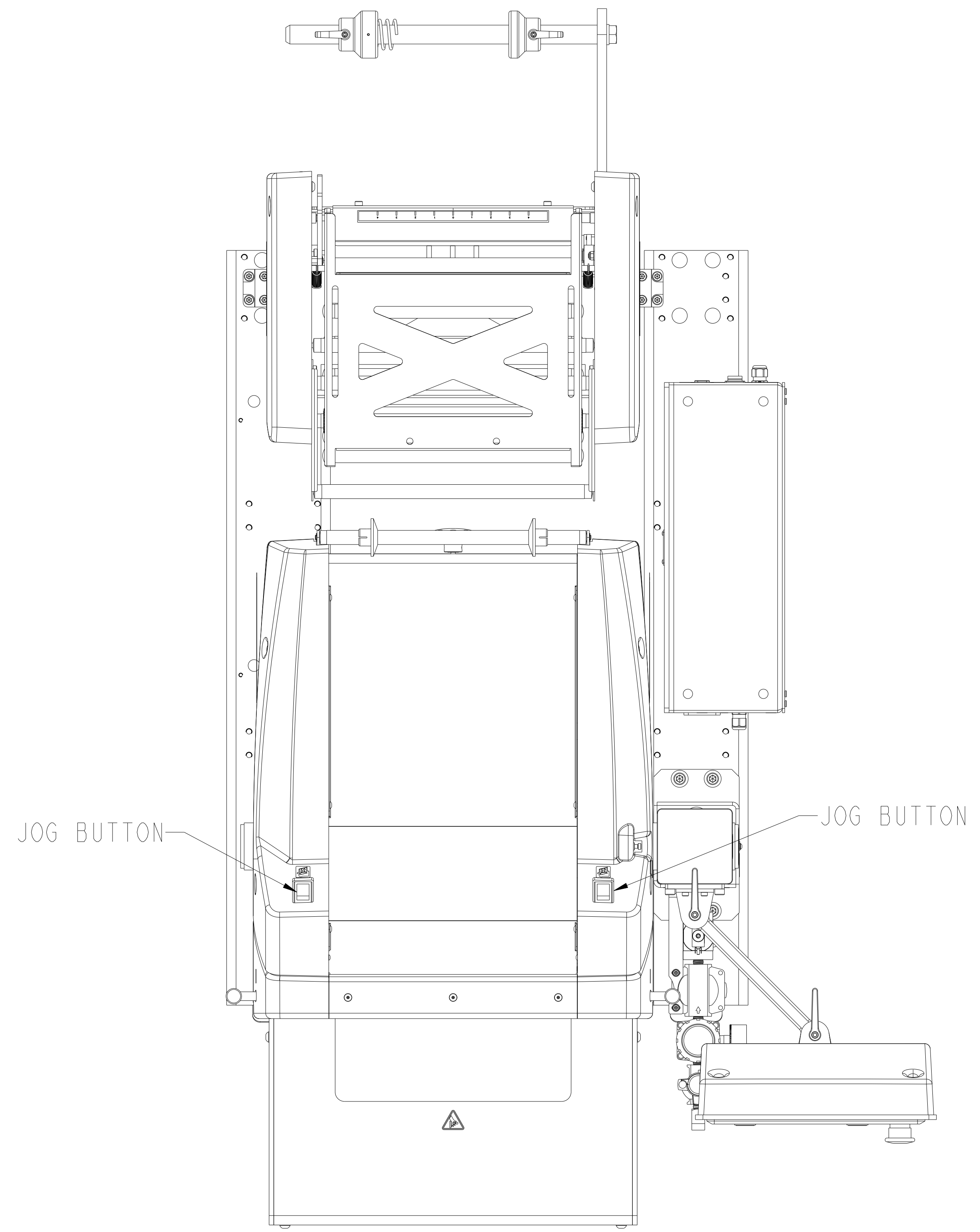

Fabricated & Documented to be RoHS Compliant

REV	BY	DATE	ECN	RELEASED	DESCRIPTION
A	DMF	10-2-16	A63	RELEASED	

FINISH	NONE				
MATERIAL	SEE B/M				
MACHINING SURFACES TO BE NO GREATER THAN 125 (3.2) ✓					
PLEASE OBSERVE NOTES					
PART MUST BE FREE OF BURRS AND SHARP EDGES					
TOLERANCES UNLESS OTHERWISE SPECIFIED:					
FRACTIONAL DIMS	FRACTIONAL DIMS				
DECIMAL DIMS	DECIMAL DIMS				
ANGLES	ANGLES				
HOLE DIMS	HOLE DIMS				
PLATE DIMS	PLATE DIMS				
THREADS	THREADS				
WELDING	WELDING				
FINISH	FINISH				
DRIVING SIZE	SCALE	DRAWN BY	DATE	DATE	DATE
E	1/4	DMF	10-2-16	10-2-16	10-2-16
TITLE		FOOTPRINT, AB 500		DRAWING NO.	
				SHEET 1 OF 1	
				FP229	